

WHAT IS SELECTIVE CATALYTIC REDUCTION (SCR)?

Selective Catalytic Reduction (SCR) is a means of converting Nitrogen Oxides (NOx) into Nitrogen (N₂) and Water (H₂O), using an injection of urea (AdBlue) with the aid of a catalyst.

Our systems are used on lean burn applications and offer a very high efficiency for the reduction of Nitrogen Oxides.

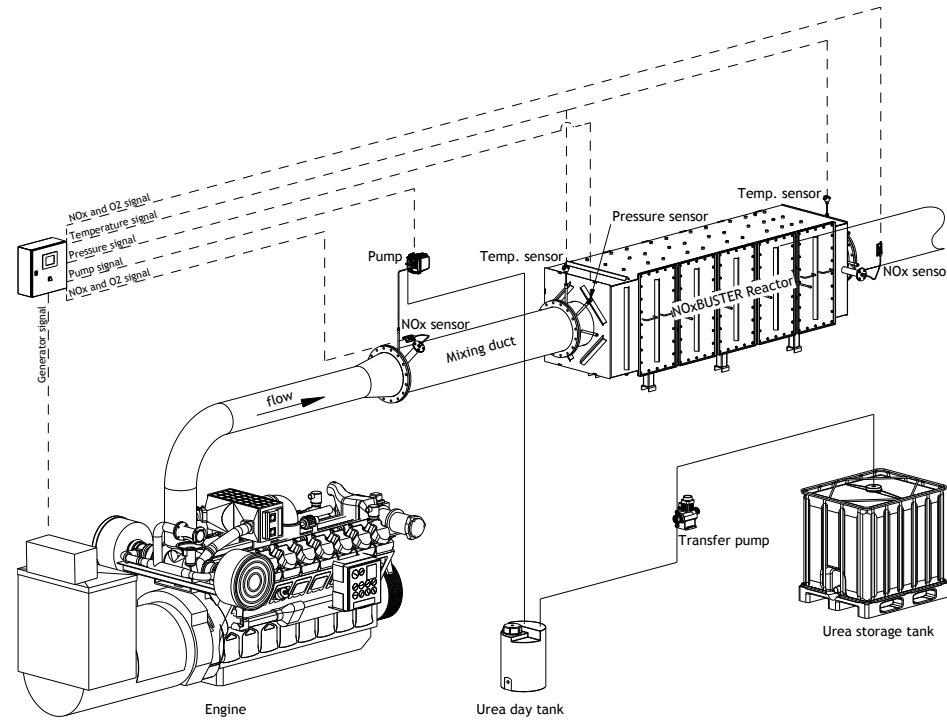

ALSO AVAILABLE

SCR BROCHURE

For all engine sizes and Backpressure Sensitive applications.



OTHER BROCHURES



Tel: +44 (0) 1342 713743 Fax: +44 (0) 1342 719181 Email: info@agriemach.com

AGRIEMACH LTD

(SCR) DENOX – SELECTIVE CATALYTIC REDUCTION SYSTEMS (UP TO 500KW)

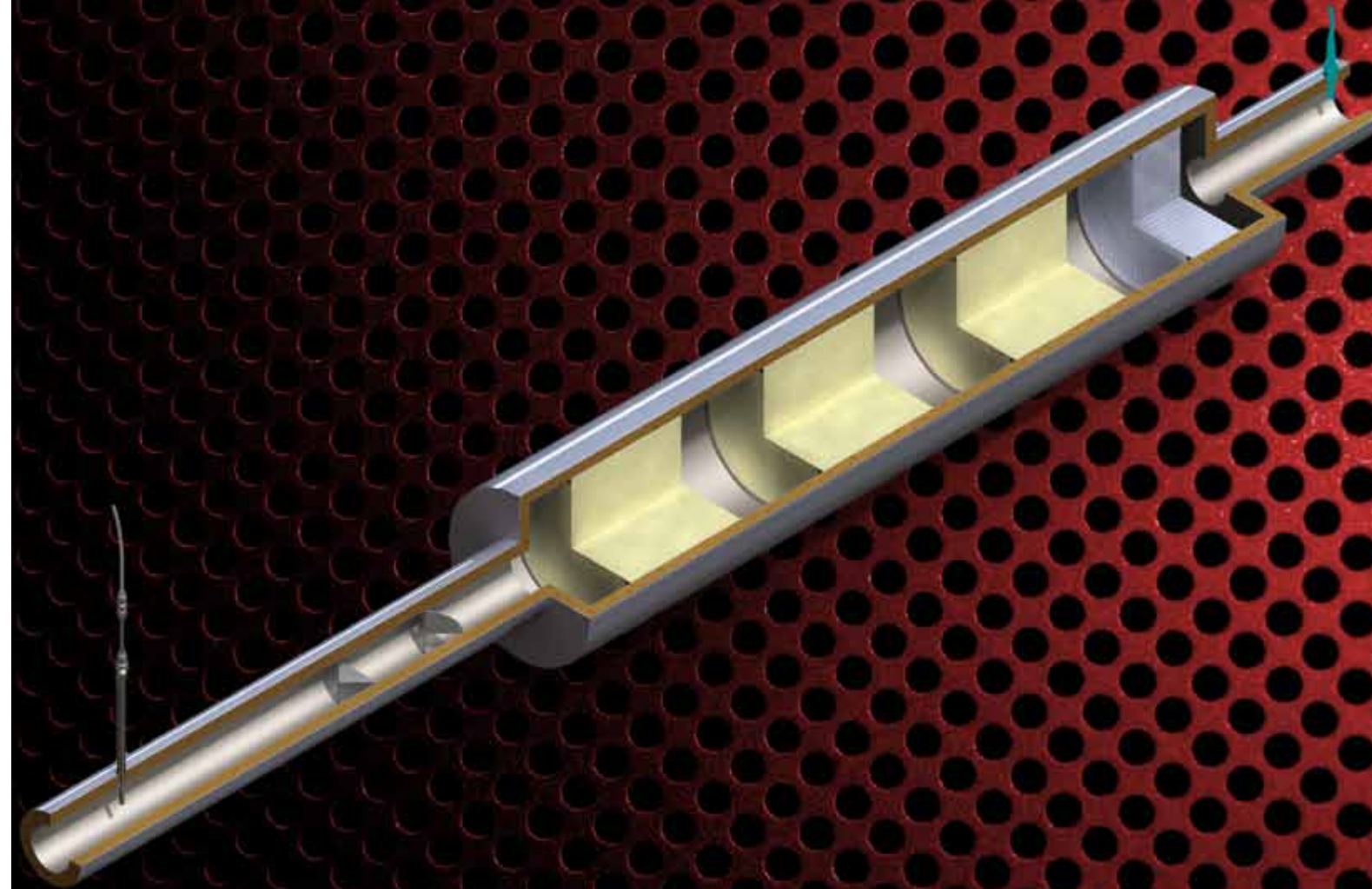

Since 1976

(SCR) DENOX – SELECTIVE CATALYTIC REDUCTION SYSTEMS (UP TO 500KW)

Agriemach Ltd offer a bespoke service for the design, manufacture and project management of Selective Catalytic Reduction Technology.

With the ever growing demand for strict exhaust emission control on a wide range of engine sizes, we have developed a smaller more compact SCR system to complement our range. Our new compact systems offer more flexibility for installations up to 500kW in size where space is at a premium. Our bespoke design service allows us to work with our customers to generate designs for both Horizontal and Vertical installations, combined Silencer and SCR assemblies to meet the strictest sound attenuation levels and with the assistance of Computational

Fluid Dynamics we are able to ensure that even the most challenging designs will offer the high reduction efficiency they are designed for.

Agriemach are also proud that both design and manufacture are controlled under one roof. Our manufacturing plant was established in 1991 and offers a wealth of experience, and has built the most SCR housings **(the world over)** in the past 20 years. This offers our customers benefits in terms of flexibility, quality and faster delivery of the finished product.



SCR urea injection

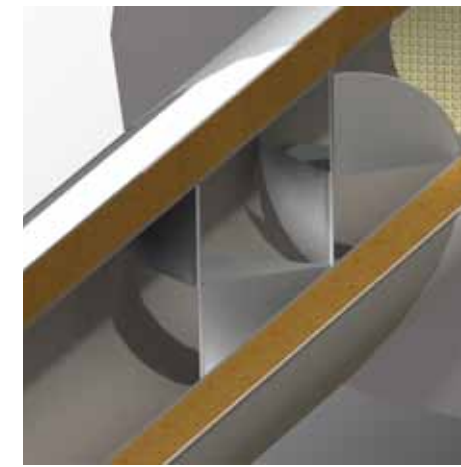

Specialist design static mixers

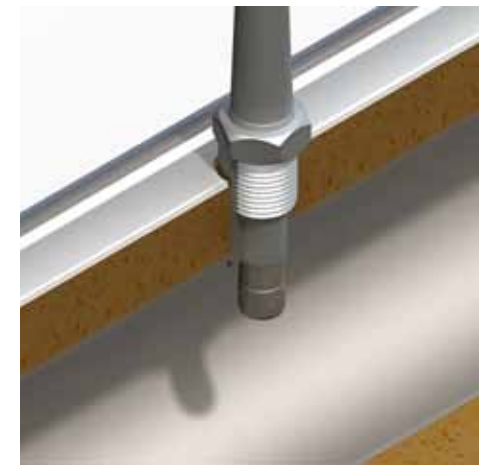

Live stream NOx sensors

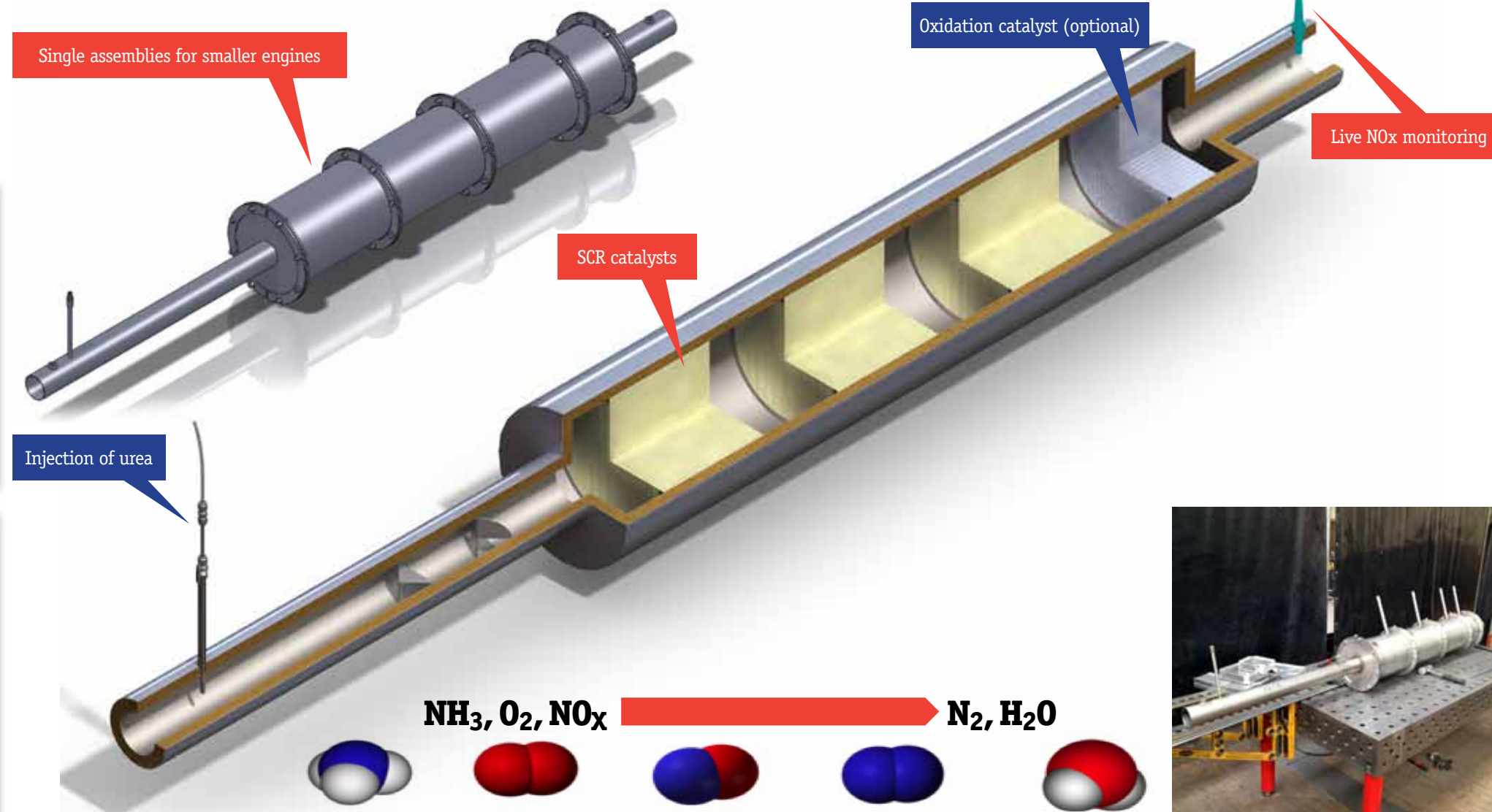
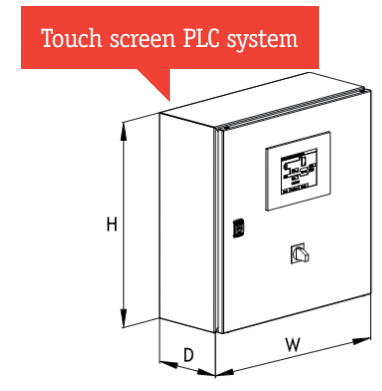
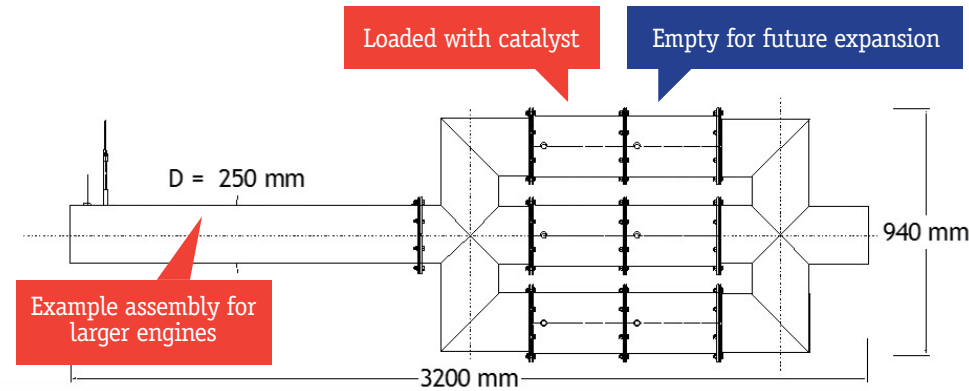

We offer complete solutions from **Factory-Fit to Retro-Fit** including all ancillary equipment required, **Project Management, Customised Designs and Guaranteed Solutions**

NO_x Reduction to as much as 98%

WHAT DO WE OFFER

- Agriemach offer a comprehensive service which includes the following:
- > Consultation
 - > Bespoke Designs
 - > Installation and Commissioning
 - > Project Management
 - > Remote Monitoring
 - > Compressors
 - > Bulk Urea Tanks
 - > Bespoke Heat Insulation Materials
 - > Oxidation Catalysts
 - > Soot Filters
 - > Delivery of Urea
 - > Training and UK Support

To date we have supplied emission control systems to engines from **80kW to 20MW** in size

