

SELECTIVE CATALYTIC REDUCTION SYSTEMS (SCR NO_x ABATEMENT)



WHAT IS SELECTIVE CATALYTIC REDUCTION (SCR)?

Selective Catalytic Reduction (SCR) is a means of converting Nitrogen Oxides (NO_x) into Nitrogen (N₂) and Water (H₂O), using an injection of urea (AdBlue) with the aid of a catalyst.

Our systems are used on lean burn applications and offer a very high efficiency for the reduction of Nitrogen Oxides.

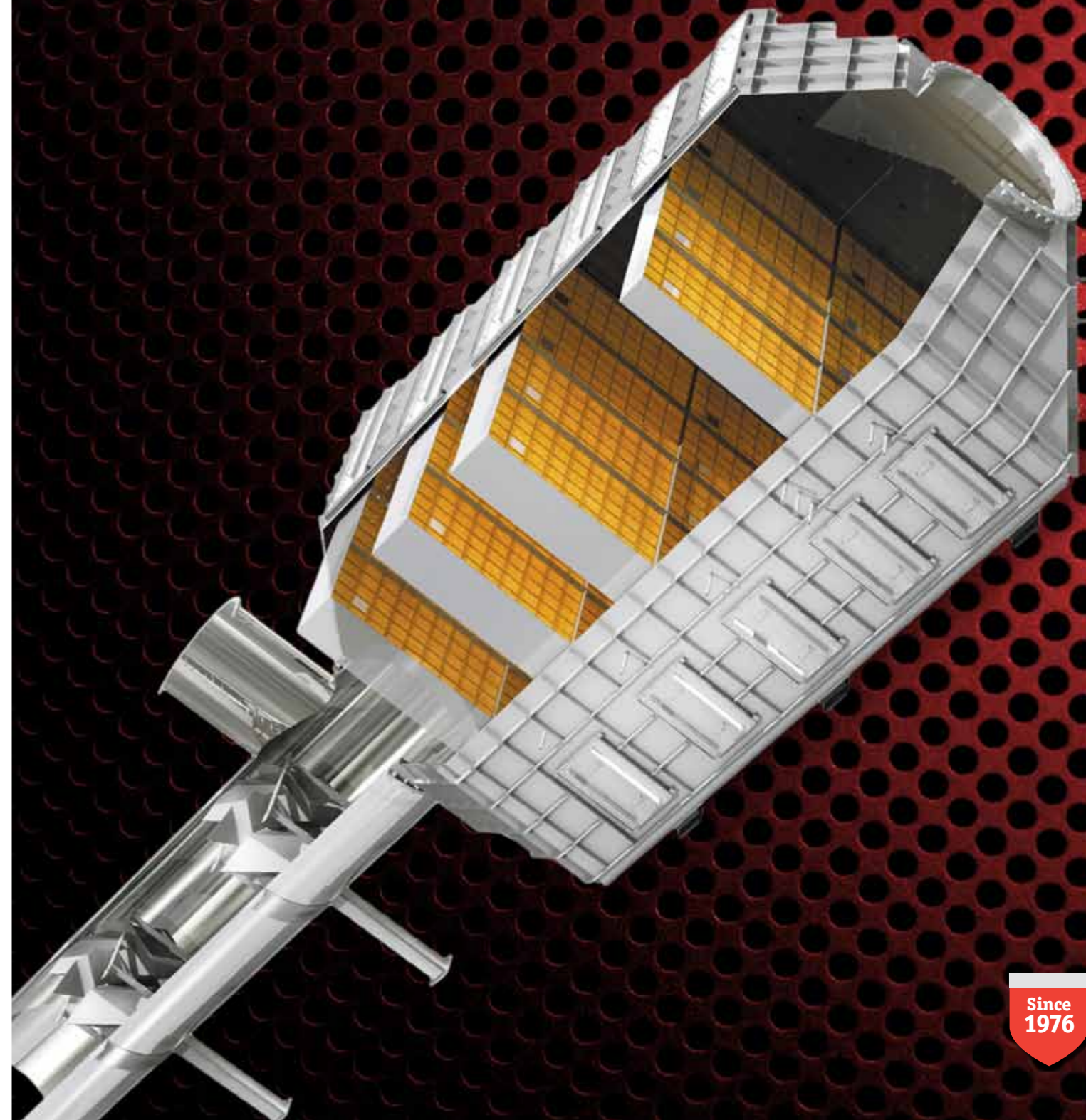
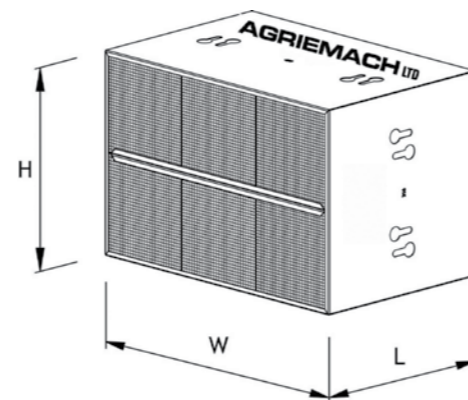
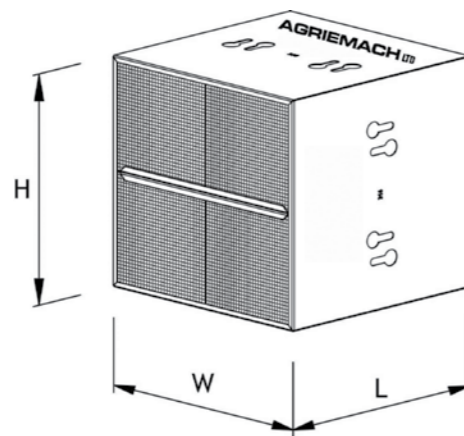
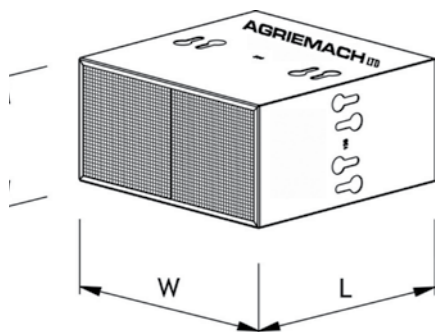

SELECTIVE CATALYTIC REDUCTION SYSTEMS (SCR NO_x ABATEMENT)

Agriemach Ltd offer a bespoke service for the design , manufacture and project management of Selective Catalytic Reduction Technology.

Offering a wealth of experience and a global knowledge base, we offer full system design, Dosing System upgrades, Catalyst Replacement and all ancillary equipment required from bulk urea tanks to Heat and Sound Insulation Materials.

We have experience with many different fuel types and the issues associated with them. We offer systems suitable for Diesel and Biodiesel engines, Natural Gas and Bio-Gas, Renewable Fuels and have designs for a multitude of engine power outputs.

We offer a full 3D CAD drawing service along with Computational Fluid Dynamics (CFD) to ensure our solution is suitable for your requirement.



MARKET AREAS

- > Power Generation
- > Cogeneration (CHP)
- > Gas Compression
- > Crop Production (Greenhouse)
- > Industrial and Chemical
- > Marine and Shipping

ENGINES CURRENTLY FITTED

- > MAN
- > Waukesha
- > MWM
- > CAT
- > Cummins
- > Deutz
- > Yanmar
- > Rolls Royce
- > Jenbacher
- > Perkins
- > Scania
- > Wartsila

ANCILLARY EQUIPMENT

- > Bulk Urea Tanks
- > Urea Distribution Lines
- > Compressors
- > Heat and Sound Insulation Materials
- > Heat Exchangers
- > Exhaust Silencers (Full Design Service)

We offer complete solutions from **Factory-Fit to Retro-Fit** including all ancillary equipment required, **Project Management, Customised Designs and Guaranteed Solutions**

NO_x Reduction to as much as 98%

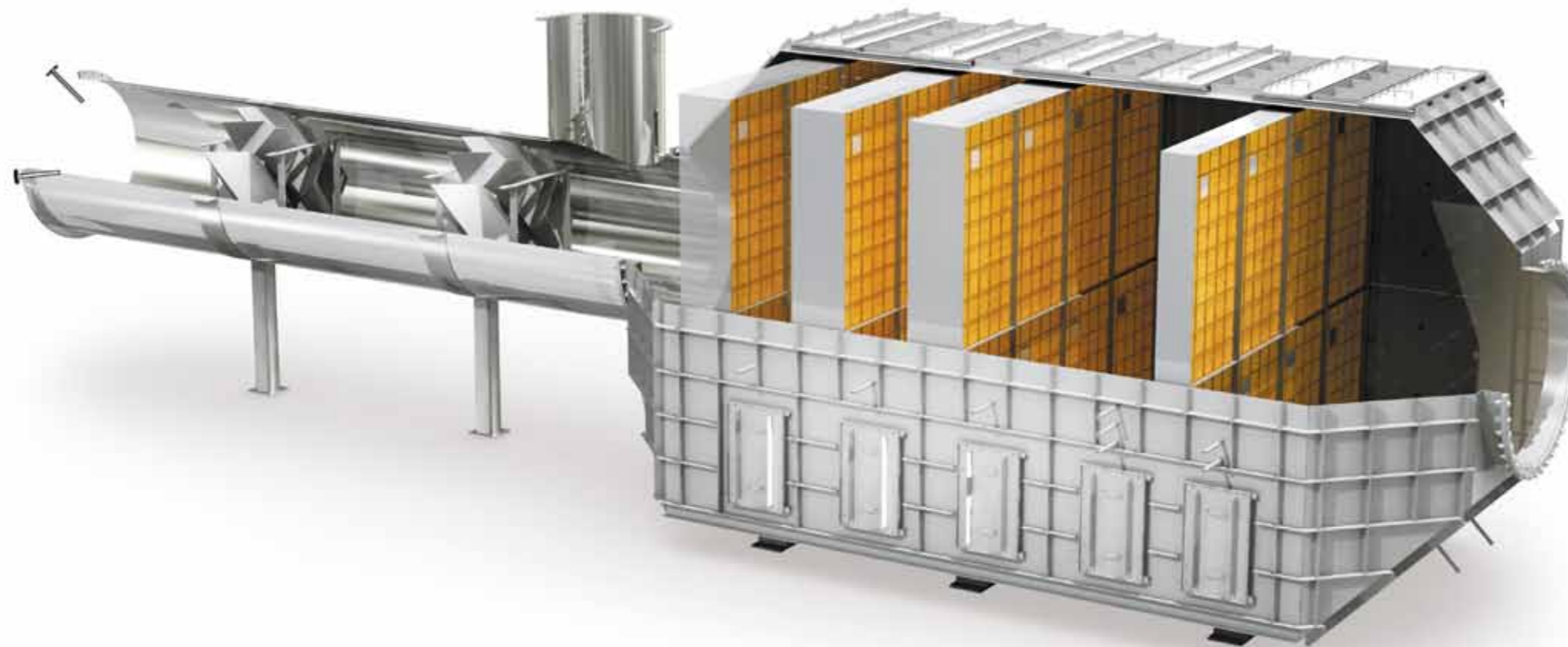

WHAT DO WE OFFER

- > Full SCR Design
- > SCR Catalysts
- > Oxidation Catalysts
- > Soot Filters
- > Dosing Systems and Upgrades
- > Project Management
- > Delivery and Installation
- > Delivery of Urea
- > Commissioning and Training
- > UK Support

To date we have supplied emission control systems to engines from **130kW to 20MW** in size

